

Exploded view for Dust Extractor 915/912

Updated 20.9.2013

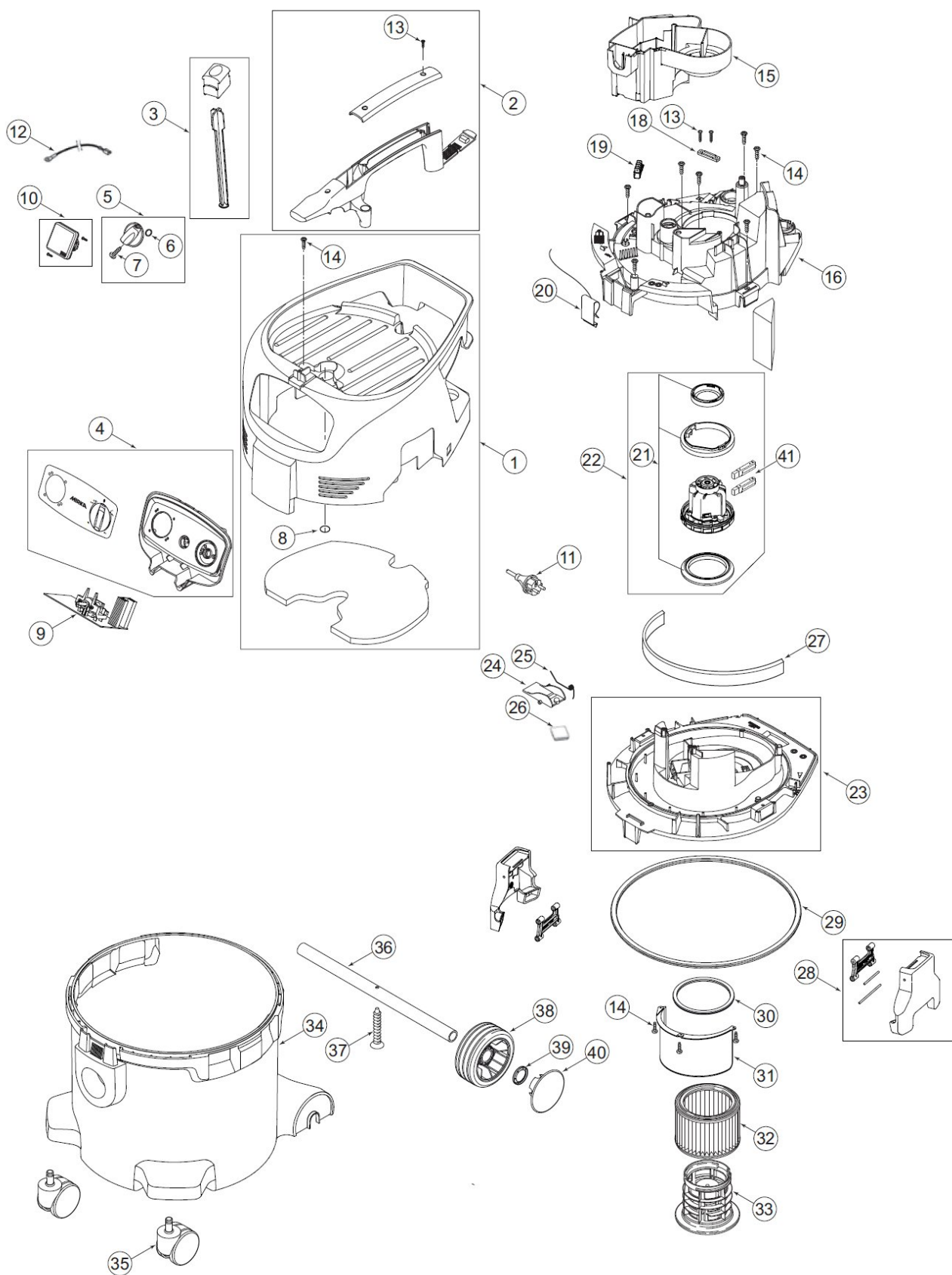

Pos	Code	QTY (pcs.)	Description	Model 912 / 915
1	8999701111	1	COVER	
2	8999710111	1	HANDLE	
3	8999700311	1	FILTER DEDUSTER	
4	8999710411	1	SWITCHBOARD	
5	8999603611	1	ROTARY KNOB	
6	8999603711	1	O-RING	
7		1	SCREW	
8		1	O-RING	
9	8999701911	1	AUTO ON-OFF SWITCH ELECTRONIC 230-240V	915
9	8999330911	1	AUTO ON-OFF SWITCH ELECTRONIC 110-120V	912*
10	8999711011	1	SOCKET (EU)	915
10	8999711011GB	1	SOCKET (GB)	915
10	8999711011	1	SOCKET (GB 110V)	915
10	8999711011GB	1	SOCKET (US)	912
10		1	SOCKET (AU)	915
11	8999711111	1	POWER CORD (EU)	915
11		1	POWER CORD (GB)	915
11		1	POWER CORD (GB 110V)	915
11	8999321111	1	POWER CORD (US)	912
11		1	POWER CORD (AU)	915
12	8999701211	1	WIRE 1 X 150 220-240V	915
12		1	WIRE 2.5 X 250 100-120 V	912*
13	8999701311	5	SCREW-SET 3.5X18	
14	8999701411	13	SCREW-SET 5x18	
15	8999701511	1	AIRGUIDE	
16	8999701611	1	CLAMPINGPLATE	
17		1	SOUND INSULATION OUTLET **	
18	8999701811	1	STRAP FOR CABLE	
19	8999711911	1	DISTRIBUTION STRIP	
20	8999702011	1	CONTACT SPRING	
21	8999702111	1	SEALING ASSEMBLY	
22	8999723211	1	MOTOR ASSAMBLY(230V)	915
22	8999322211	1	MOTOR ASSAMBLY(110-120V)	912*
23	8999702311	1	BASEPLATE	
24	8999702411	1	FLAP	
26	8999602211	1	SPRING	
26	8999702611	1	PLUG BASE PLATE BASIC	
27		1	SOUND INSULATION FRONT	
28	8999702811	2	CONTAINER CLAMP	
29	8999702911	1	GASKET FOR CONTAINER	
30	8999601411	1	GASKET FOR FILTER	
31	8999703111	1	DEFLECTOR	
32	8999600411	1	FILTER	
33	8999602511	1	FILTER SUPPORT CAGE	

34	8999703411	1	CONTAINER WITH FITTING
35	8999703511	2	CASTER
36	8999703611	1	WHEEL AXLE
37	8999703711	1	SCREW 5X35
38	8999601511	2	WHEEL
39	8999703911	2	RING
40	8999704011	2	HUB CAP
41	8999723511	2	CARBON BRUSHES (2 pcs)

*

also used for MIRKA 915 GB 110V

**

not shown